

Sample Transfer & Manipulation

Section Eight



8

8.1	General Information	2
8.2	Sample Transfer System & Load Lock Chamber	4
8.3	Add-A-Doors	5
8.4	Manipulators, Stages & Translators	6
8.5	Utility Hat & Alignment Gimbals	8
8.6	Motion Feedthroughs	9
8.7	Wobble Sticks	14

Nor-Cal Products, Inc.
P. O. Box 518
1967 So. Oregon
Yreka, CA 96097 USA

Tel: **800-824-4166**
or 530-842-4457
Main Fax: 530-842-9130
Sales Fax: 530-841-9189
www.n-c.com



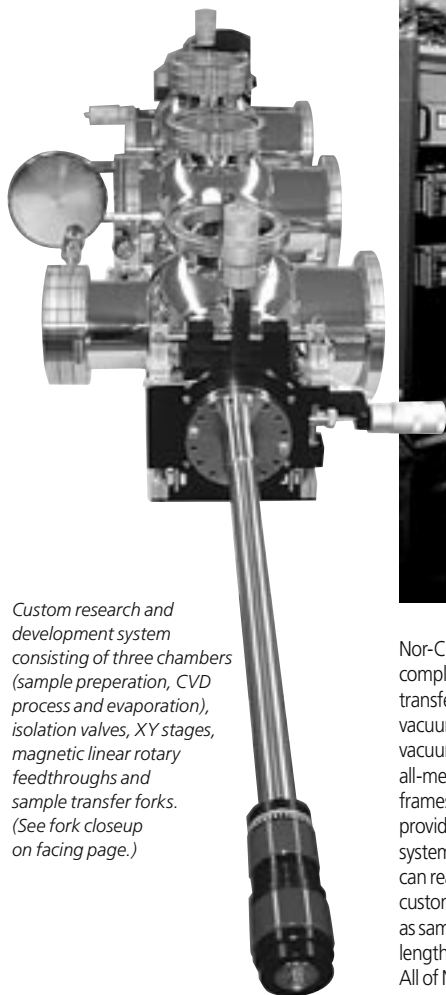

Custom research and development system consisting of three chambers (sample preparation, CVD process and evaporation), isolation valves, XY stages, magnetic linear rotary feedthroughs and sample transfer forks. (See fork closeup on facing page.)



Surface science research at Advanced Light Source, Berkeley, California

Nor-Cal Products offers the researcher complimentary devices for sample transfer and positioning in ultra-high vacuum systems. Combined with our vacuum chambers, load locks, gate valves, all-metal valves, feedthroughs, viewports, frames and roughing accessories, we can provide a complete turn-key research system. Each standard component can readily be customized to meet our customer's specific requirements, such as sample heating and cooling, special lengths or stepper motor drivers. All of Nor-Cal's sample transfer and manipulation devices are made from the highest quality materials and lubricants to withstand repeated UHV bakeouts.

When selecting a sample handling system, consideration must be given to its operation with goniometers and precision gearboxes. These devices typically require that the sample be solidly held and moved in a precise way. The sample platen must be docked to a goniometer so as not to limit the degrees of freedom or degrade the goniometer's resolution.

Selecting a Sample Transfer System

The following list contains some of the many factors that influence the selection of a sample transfer system, which vary by application.

- Sample motion requirements
- Heating requirements
- Cooling requirements
- Sample size
- Size of chamber tubulations available
- Geometry of the chambers relative to manipulators and type of transfer translator and load-lock
- Motion available for actuation
- Compatibility with existing or planned equipment
- Ease and reliability of operation

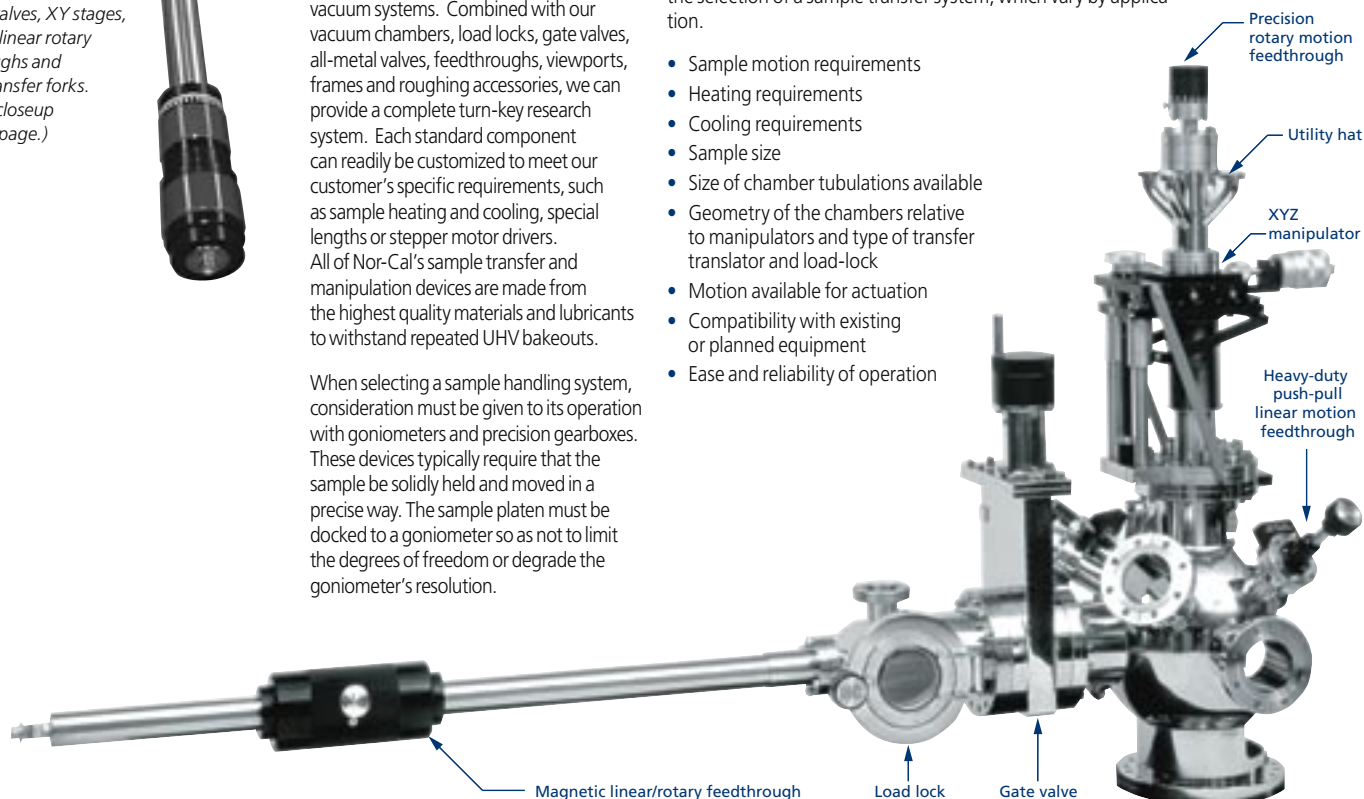

All dimensions are in inches unless otherwise noted

Prices subject to change without notice. - International product pricing will vary.

Ultra-High Vacuum Components Since 1962 • 800-824-4166 • www.n-c.com

XYZ Manipulator

A manipulator is a 3-axis (X,Y,Z) positioning device. For most applications, the instrument hardware is mounted outside the vacuum chamber, with a welded bellows providing a flexible vacuum curtain. The X axis passes in front of the vertical, mechanical structure, or "backframe," with the Y axis moving to and away from the backframe. The Z axis is perpendicular to the X and Y axes and moves up and down directly against the vacuum pressure differential. The polar axis is the same as the Z axis.

The limit of X and Y travel is normally a circular pattern. Range is indicated as a vector sum. This means a $\pm .50$ inch range of X and Y allows the polar axis to be moved anywhere inside a 1.00 inch diameter circle. The sum of the X and Y vectors is limited to .50 inch. Square pattern XY stages are available as options on some models.

Z Translator

A translator is a single axis positioning device, utilizing a bellows as a vacuum seal. Referred to as a "Z only" stage, this axis is normally perpendicular to the chamber. This causes the Z axis to work directly against the force from the pressure differential.

XY Stage

The XY stage provides the X and Y axes only. No Z motion is available.

Polar Rotation

The polar axis is the same as the Z axis. Rotation about the polar axis is commonly achieved by mounting a rotary feedthrough at the center of the traveling flange of a manipulator or translator. This degree of freedom can also be achieved with a differentially pumped rotary seal.

Azimuthal Axis

The azimuthal axis is perpendicular to the polar axis. Sample azimuthal rotation refers to rotation of the sample about an axis normal to the sample face and perpendicular to the polar axis.

Tilt Motion

Tilt refers to changing the polar axis with respect to the X, Y and Z axes. This is usually done at the traveling flange of a 3-axis manipulator or other exterior mounting stage. Tilt range is often limited by the bellows ID and the OD of the probe passing through the bellows. The maximum angle practical is about $\pm 7^\circ$. When used in this manner, translation in X, Y and (slightly) Z will occur with adjustment of the tilt angle. Tilt stages are available in single or dual axis units.

Flip Motion

Flip motion is the changing of an axis normal to the sample face from parallel (or coaxial) to the polar axis to coaxial with the azimuthal axis. The range of this change of axis may be 90° , 180° or full 360° .

Sample Transfer and Heating

Sample transfer may reduce heating performance at high temperatures. The ideal transfer system for heating the sample to the highest temperatures should use thin sample plates made of appropriate material placed as close to the heater as possible. Thick, high mass, sample plates reduce thermal response and lower peak heating temperatures.

Sample Transfer and Cooling

Sample transfer may reduce cooling performance at low temperatures. The ideal transfer system for cooling the sample to the lowest temperatures should use thin, highly conductive, sample plates that contact the dewar with a large surface area. Thick, high mass, sample plates reduce thermal response and reduce peak cooling performance.

Transfer Components

- **Sample Platen** — the transferable plate that holds the sample
- **Sample Fork** — attaches to a transfer arm from the load-lock and holds the sample platen

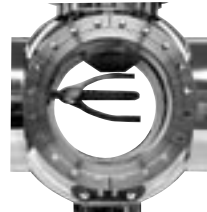

Sample transfer fork

- **Sample Dock** — attaches to a work station (manipulator) and holds the platen for processing or positioning the sample

Fork and Dock Configurations

- **Axial Fork** — a sample fork with the plane of the sample platen face orthogonal to the axis of the transfer arm on which the fork is mounted
- **Radial Fork** — a sample fork with the plane of the sample platen face parallel to the axis of the transfer arm on which the fork is mounted
- **Axial Dock** — a sample dock with the plane of the sample platen face orthogonal to the axis of the manipulator on which the dock is mounted
- **Radial Dock** — a sample dock with the plane of the sample platen face parallel to the axis of the manipulator to which the dock is mounted

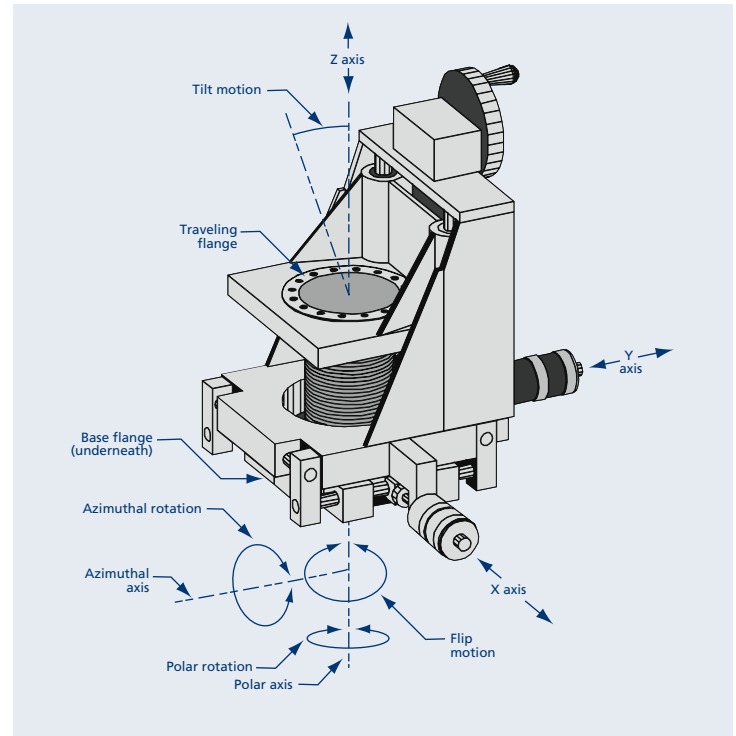

Types of Motion Used For Transfer Actuation

- **Linear Motion** — linear movement of the sample along any axis
- **Rotary Motion** — rotary motion about any axis
- **Tilt Motion** — angular positioning movement of the horizontal or orthogonal axis. The weight of the sample, plate, fork and translator can cause deflection that misaligns the axis of transfer. A tilt stage can be used to re-align the axis to enable a transfer

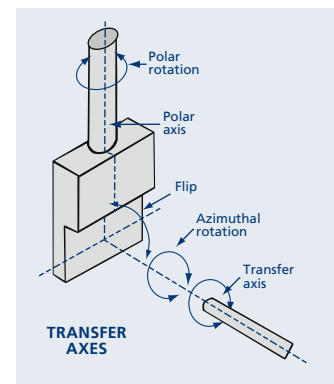

Bolt Pattern Orientation

Our components are manufactured with the primary axis straddling adjacent bolt holes on the mounting flange (American standard). Most components can be furnished with the axis passing through a bolt hole axis (European standard) on request. Some equipment is field adjustable.

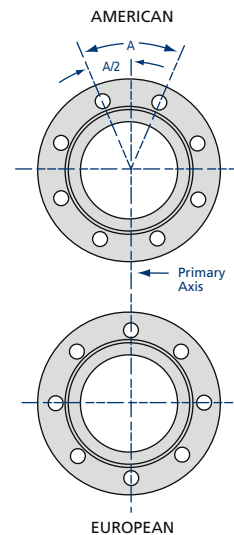



Sample Transfer & Manipulation

Sample Transfer System & Load Lock Chamber

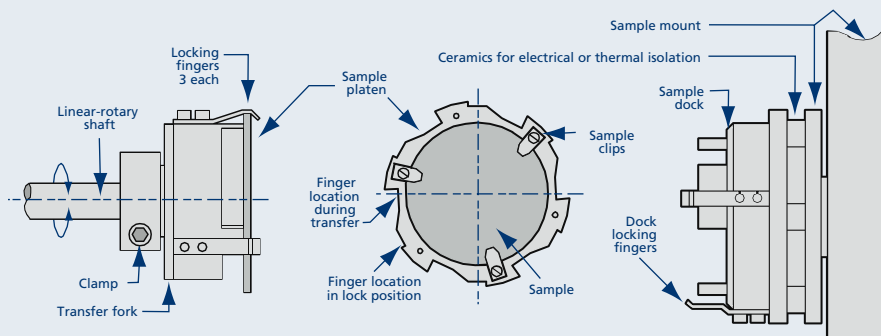

STS Sample Transfer Systems are manufactured and protected under the following patent: 5,705,128.

Sample Transfer System

This sample transfer system uses thin (.040 inch) sample plates with six sawtooth shaped ramps, profiled on the plate's edge. The sample transfer probe is fitted with a fork consisting of three tab-shaped spring fingers positioned radially on a barrel. The sample plate locks on to the fork by rotating the fork's fingers over three of the six ramps. When the fork is rotated, the locking fingers slide up the ramps to stops. The plate is gripped by the spring fingers, holding it tight to the barrel of the fork.

Transferring the sample from the probe fork to a manipulator sample dock is done with a rotary motion. The dock has the same type of locking fingers as the fork. The plate is mated to the dock by orienting it so that the three unused ramps can receive the dock's fingers. Rotating the fork releases the plate at the same time the fingers on the dock grip and lock the plate to the manipulator. This rotary movement makes a smooth sample transfer from the fork to dock and back again.

Nor-Cal's sample transfer system allows easy, forgiving sample transfer from a rotary/linear feedthrough to the sample dock mounted inside the chamber. Systems are available for sample sizes ranging from 1/2 inch to 3 inches. Each system includes a dock assembly custom fitted to place the sample on target in your particular chamber, a transfer fork assembly which mounts to a rotary/linear device and two stainless steel sample plates. Molybdenum sample plates are also available. Call for details and pricing.

Features

- Fast thermal response and greater extremes
- Larger samples may be introduced through smaller ID plumbing
- Excellent sample plane repeatability
- Adapts to most goniometers and precision gearboxes
- Excellent performance for direct and indirect cooling
- Transferable thermocouple, optional
- Transferable intrinsic direct heating
- Five-year guarantee

MODEL NUMBER	SAMPLE OD	MINIMUM PORT OD
STS-050	1/2	1 1/2
STS-100	1	1 1/2
STS-200	2	2 1/2
STS-300	3	4

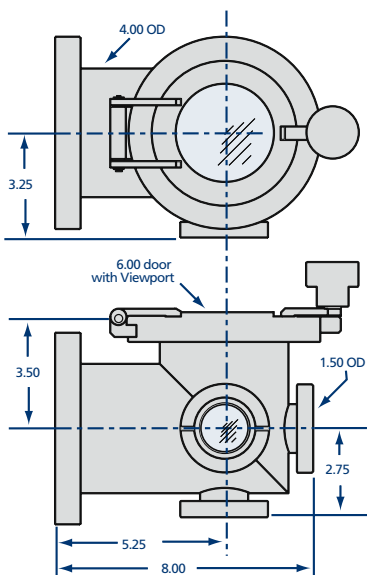

Load Lock Chamber

Load lock chambers are an efficient means to introduce a sample into a vacuum chamber without impacting the main chamber vacuum. Load Locks are provided with a six inch CF flange for mounting to the gate valve, a six inch Add-A-Door with 7056 glass viewport, a 2 3/4 inch CF flange for attachment of the linear feedthrough, and two 2 3/4 inch CF flanges for pumping and gauges. Standard finish is electropolished. Custom sizes and configurations are readily available. Call for pricing.

MODEL NUMBER	PRICE
LL-600-ADV-150-3	\$ 1575.00

SPECIFICATIONS

Construction
 Flanges: 304 stainless steel
 Body: 304 stainless steel
 Viewport: 7056 glass
 O-ring: Viton

Temperature range: -20°C to 200°C

Vacuum range: ≥ 10⁻⁸Torr - High vacuum



Prices subject to change without notice. - International product pricing will vary.

Ultra-High Vacuum Components Since 1962 • 800-824-4166 • www.n-c.com



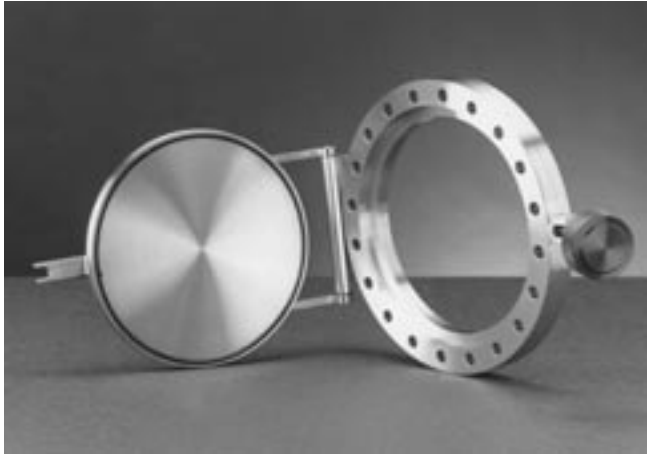
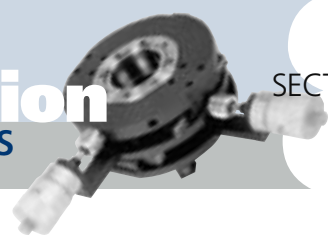

An Add-A-Door can provide easy access to a vacuum system when elastomer seals are acceptable. The hinged, Viton sealed door is quickly bolted to an existing CF (Conflat style) flanged chamber port. The door is opened easily by turning a knurled knob. These doors are available for 2³/₄ to 10 inch OD flanges with a solid metal door or with a viewport. Standard finish is electropolished. Custom sizes can be supplied upon request.

SPECIFICATIONS

Construction

Body: 304 stainless steel
 Flange: 2³/₄ to 10 inch CF
 Door: Blank, 7056 glass, or fused silica
 O-ring: Viton standard

Temperature range: -20°C to 200°C

Vacuum range: ≥ 10⁻⁸Torr - High vacuum

Add-A-Doors

MODEL NUMBER	FLANGE TYPE	A	B
AD-275	2.75 CF	1.380	0.500
AD-450	4.50 CF	2.435	0.687
AD-600	6.00 CF	3.917	0.781
AD-800	8.00 CF	5.875	0.875
AD-1000	10.00 CF	7.875	0.968

Add-A-Doors with Viewport – 7056 Glass

MODEL NUMBER	FLANGE TYPE	A	B	C
ADV-450	4.50 CF	2.435	0.69	1.49
ADV-600	6.00 CF	3.917	1.00	2.65
ADV-800	8.00 CF	5.875	1.20	3.88
ADV-1000	10.00 CF	7.875	1.30	5.60

Add-A-Doors with Viewport – Fused Silica

MODEL NUMBER	FLANGE TYPE	A	B	C
ADVQ-450	4.50 CF	2.435	0.74	1.40
ADVQ-600	6.00 CF	3.917	1.02	2.69
ADVQ-800	8.00 CF	5.875	1.21	3.88
ADVQ-1000	10.00 CF	7.875	1.28	5.38

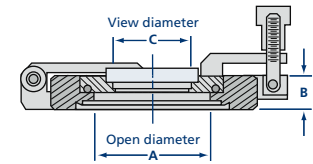
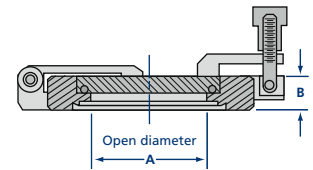
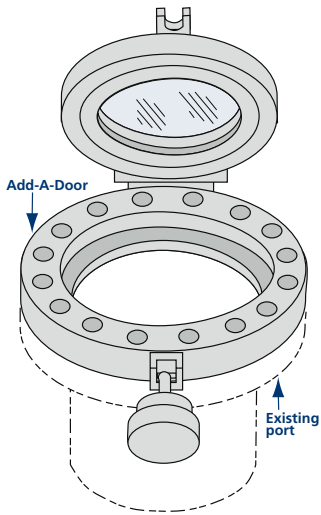

Viewport Optical Transmission Curves

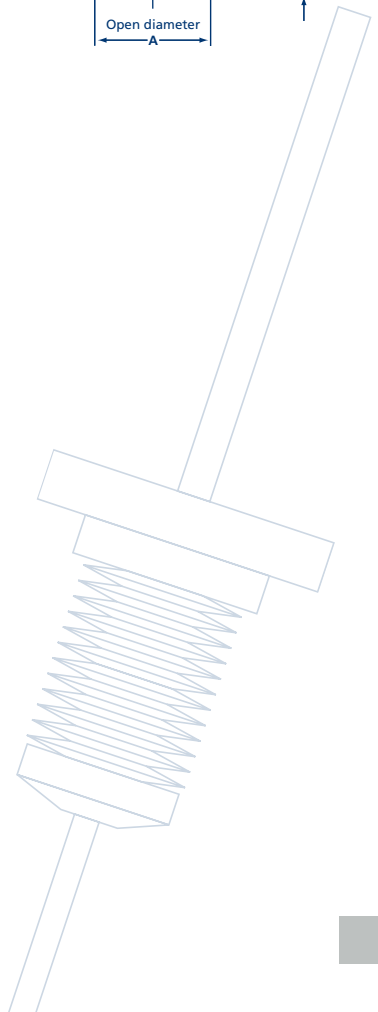
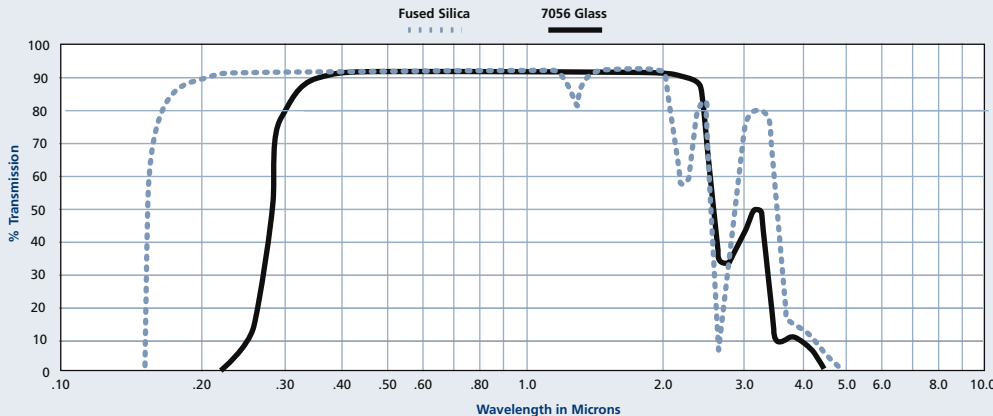



Sample Transfer & Manipulation

Manipulators, Stages & Translators

SPECIFICATIONS

Construction

Bellows: 17/8 inch ID
Base flange: 6 inch CF, clearance holes with 5 mini flanges
Travelling flange: 23/4 inch CF, tapped holes
Guide rods: Dual 3/4 inch OD hardened stainless steel
Stage: Aluminum

Motion

XY travel: ± 1/2 inch, circular pattern, pre-loaded large drum micrometer stage coupling with 0.0001 inch divisions
Z travel: 2 inch, Acme drive with 2 inch diameter drive knob (0.10 inch per turn)

Operating orientation: Any; maximum payload 10lbs. when horizontally mounted

Temperature

Maximum bakeout: 150°C, fully assembled
Operating: 20°C (ambient)

Vacuum range: ≥ 10⁻¹⁰Torr - UHV

Options: Support tube

Guarantee: Five years

XYZ Precision Manipulator

The PMXYZ manipulator provides high precision positioning at a minimum cost. It features precision pre-loaded cross-roller stage control with pre-loaded micrometer-to-stage coupling. The X-Y guide system is made of hardened carbon steel. Support tube option includes a 3/4 inch OD tube and end bearing support. This increases rigidity on longer rotary shafts.



ity

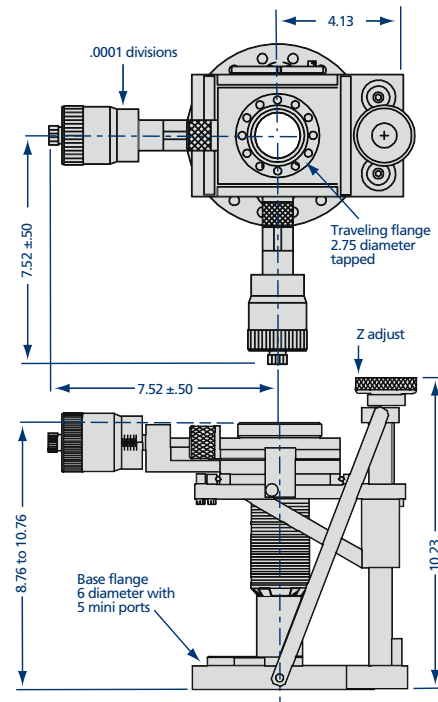

MODEL NUMBER

DESCRIPTION

PMXYZ-600-1.87-2	XYZ manipulator
-ST.25	1/4 inch rotary shaft support tube*
-ST.38	3/8 inch rotary shaft support tube*

XY Stages with Bellows

XY stages are used to provide precise two-axis sample transfer positioning.

SPECIFICATIONS

Construction

Bellows: Edge welded stainless steel
Base flange: CF, clearance holes
Travelling flange: CF, tapped holes
Way bearings: Precision linear

Motion

XY travel: ± 1/2 to 1 inch, circular pattern, pre-loaded large drum micrometer stage coupling with 0.0001 inch divisions

Operating orientation: Any; maximum payload 10 lbs when horizontally mounted

Temperature

Maximum bakeout: 150°C, fully assembled
Operating: 20°C (ambient)

Vacuum range: ≥ 10⁻¹⁰Torr - UHV

Guarantee: Five years

MODEL NUMBER	FLANGE TYPE	BELLOWS ID	XY TRAVEL	A	B	C	D	E
PMXY-275-139-1	23/4 CF	1.39	± 1/2	7.386	5.000	5.000	4.100	7.386
PMXY-450-200-1	41/2 CF	2.00	± 1/2	9.250	7.750	7.750	5.400	9.250
PMXY-450-250-1	41/2 CF	2.50	± 1/2	9.250	7.750	7.750	5.400	9.250
PMXY-450-250-2	41/2 CF	2.50	± 1	9.250	7.750	7.750	5.400	9.250
PMXY-600-300-1	6 CF	3.00	± 1/2	11.960	9.875	9.312	6.530	11.087
PMXY-600-300-2	6 CF	3.00	± 1	11.960	9.875	9.312	6.530	11.087
PMXY-600-400-1	6 CF	4.00	± 1/2	11.960	9.875	9.312	6.530	11.087
PMXY-600-400-2	6 CF	4.00	± 1	11.960	9.875	9.312	6.530	11.087

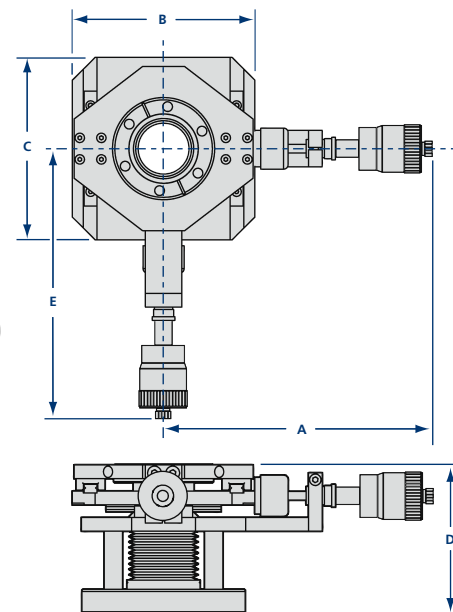

Prices subject to change without notice. - International product pricing will vary.

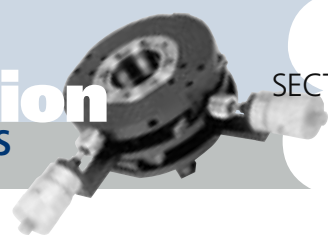

Z-Translators

Z translators feature a compact yet stable linear motion design, suitable for a variety of applications including use with our differentially pumped rotary seals. They may also be used with feedthrough utility hats and rotary motion feedthroughs.

MODEL NUMBER	DIAGRAM	TRAVELING FLANGE	BELLOWS ID	Z STROKE	BASE FLANGE	A	B	C	MIN.-MAX. D & E
MZ-275-104-2	A	2 ³ / ₄	1.04	2	2 ³ / ₄	3.060	6.94	1.750	Call
MZ-275-104-4	A	2 ³ / ₄	1.04	4	2 ³ / ₄	3.060	6.94	1.750	Call
MZ-275-104-6	A	2 ³ / ₄	1.04	6	2 ³ / ₄	3.060	6.94	1.750	Call
MZ-275-153-2	A	2 ³ / ₄	1.53	2	2 ³ / ₄	3.060	6.94	1.750	Call
MZ-275-153-4	A	2 ³ / ₄	1.53	4	2 ³ / ₄	3.060	6.94	1.750	Call
MZ-275-153-6	A	2 ³ / ₄	1.53	6	2 ³ / ₄	3.060	6.94	1.750	Call
MZ-450-188-2	A	2 ³ / ₄	1.88	2	4 ¹ / ₂	3.250	6.94	1.750	Call
MZ-450-188-4	A	2 ³ / ₄	1.88	4	4 ¹ / ₂	3.250	6.94	1.750	Call
MZ-450-188-6	A	2 ³ / ₄	1.88	6	4 ¹ / ₂	3.250	6.94	1.750	Call
MZ-450-250-2	A	4 ¹ / ₂	2.50	2	4 ¹ / ₂	3.250	6.94	1.750	Call
MZ-450-250-4	A	4 ¹ / ₂	2.50	4	4 ¹ / ₂	3.250	6.94	1.750	Call
MZ-450-250-6	A	4 ¹ / ₂	2.50	6	4 ¹ / ₂	3.250	6.94	1.750	Call
MZ-600-300-2	B	6	3.00	2	6	8.85	-	9.97	Call
MZ-600-300-4	B	6	3.00	4	6	8.85	-	9.97	Call
MZ-600-300-6	B	6	3.00	6	6	8.85	-	9.97	Call
MZ-600-400-2	B	6	4.00	2	6	8.85	-	9.97	Call
MZ-600-400-4	B	6	4.00	4	6	8.85	-	9.97	Call
MZ-600-400-6	B	6	4.00	6	6	8.85	-	9.97	Call

SPECIFICATIONS

- Construction**
 Bellows: 1.04 to 4 inch ID edge welded stainless steel
 Base flange: 2³/₄ to 6 inch CF, clearance holes
 Travelling flange: 2³/₄ to 6 inch CF, tapped holes
 Guide rods: Dual 3/4 inch OD hardened stainless steel
 Stage: Aluminum
- Motion:** 2 to 6 inches Z travel, Acme drive with position indicator scale
- Operating orientation:** Any
- Temperature**
 Maximum bakeout: 150°C, fully assembled
 Operating: 20°C (ambient)
- Vacuum range:** ≥ 10⁻¹⁰Torr - UHV
- Guarantee:** Five years

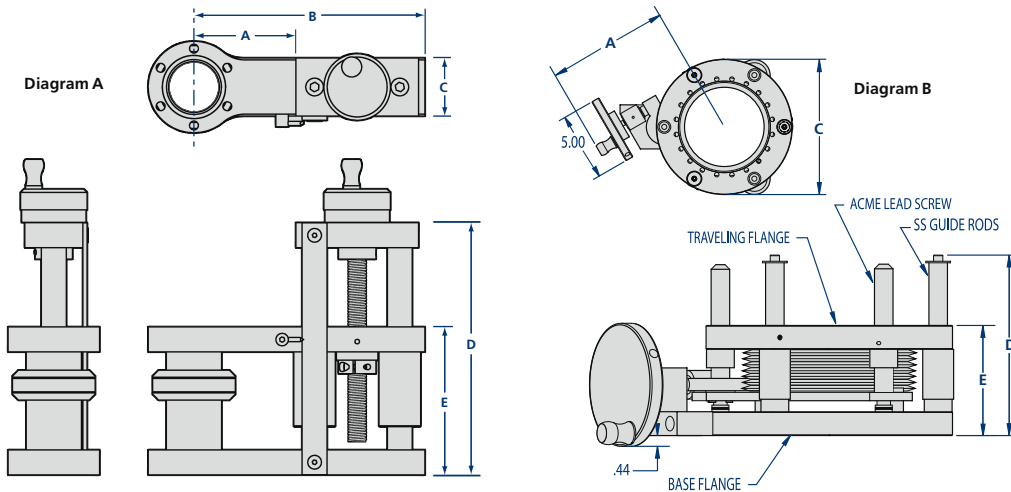

Linear Motion Thimbles

The compact design and reliable operation of these linear motion thimbles allows precision linear probe positioning to distances up to two inches. Features include a clear bore design with a stainless steel welded bellows. Anodized aluminum collar is threaded to perform linear movement.

MODEL NUMBER	NOMINAL OD A	MINIMUM - MAXIMUM B	ID
LMT-133	1 ³ / ₄	1.800 - 2.800	0.54
LMT-275	3 ¹ / ₄	3.060 - 5.060	1.43

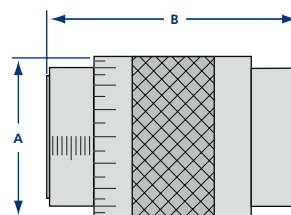

SPECIFICATIONS

- Construction**
 Bellows: 0.54 or 1.43 inch ID stainless steel
 Flanges: 1¹/₃ or 2³/₄ inch CF, tapped holes
 Collar: Anodized aluminum
- Motion:** Up to 2 inches linear movement, 360° graduations laser engraved on the collar
- Temperature range:** -20°C to 350°C
- Vacuum range:** ≥ 10⁻¹⁰Torr - UHV



Sample Transfer & Manipulation

Utility Hat & Alignment Gimbals

SPECIFICATIONS

Construction

Material: 304 stainless steel
Flanges: CF, tapped and clearance holes
see diagram for details
Finish: Electropolished

Operating orientation: Any

Temperature range: -200°C to 450°C

Vacuum range: $\geq 10^{-10}$ Torr - UHV

Utility Hat

Feedthroughs can be mounted to the base flange of the XYZ Manipulator or to a utility hat. A utility hat is the preferred method when X-Y movements of the sample will cause excessive flexing and abrading of utility lines in vacuum. The utility hat can be mounted between the precision rotary feedthrough and the traveling flange on top of the XYZ to provide X-Y movement of utility lines with the sample. Additionally, the utility hat can be used on top of a differentially pumped rotary seal to allow 360° polar rotation of utility lines along with the sample. (See photo next page.) The standard utility hat comes with a 1 $\frac{3}{4}$ inch tube, two 2 $\frac{3}{4}$ inch CF flanges and four 1 $\frac{1}{3}$ inch CF ports for mounting feedthroughs. Standard finish is electropolished. Custom sizes can be supplied upon request.

MODEL NUMBER

UH-175-2-133-4

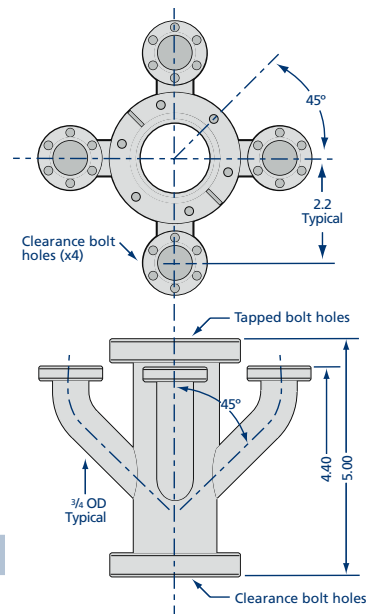

SPECIFICATIONS

Construction

Bellows: 1 $\frac{1}{2}$ inch ID stainless steel
Flanges: 2 $\frac{3}{4}$ inch CF, tapped holes
Pivots: Roller bearing

Motion: $\pm 5^\circ$ XY adjustment range,
knurled knob adjustment

Operating orientation: Any

Temperature

Maximum bakeout: 200°C
Operating: 20°C (ambient)

Vacuum range: $\geq 10^{-10}$ Torr - UHV

Options: Micrometers "-M1" and "-M2"

Guarantee: Five years

Alignment Gimbals

Alignment gimbals allow a precise angle alignment to be established (and repeated) between two flanges. When the base flange of a gimbal is attached to the chamber flange (or traveling stage of a positioning device) and a probe is attached to the tilting flange, probe angle and tip position can be changed. Alignment gimbals were designed as an inexpensive method to align docking systems and actuate sample transfers. Gimbals cantilever the (horizontal) load when the linear feedthrough flange and the load lock are horizontally mounted and can also compensate for droop in long horizontal mounted linear feedthrough probes. Single axis alignment gimbals are also available. Call for pricing and availability.

MODEL NUMBER

DESCRIPTION

AG-275-150	Knurled knob adjustment on both axes
AG-275-150-M1	Micrometer adjustment on one axis, knurled knob on the other axis
AG-275-150-M2	Micrometer adjustment on both axes



Shown with micrometer option "-M2"

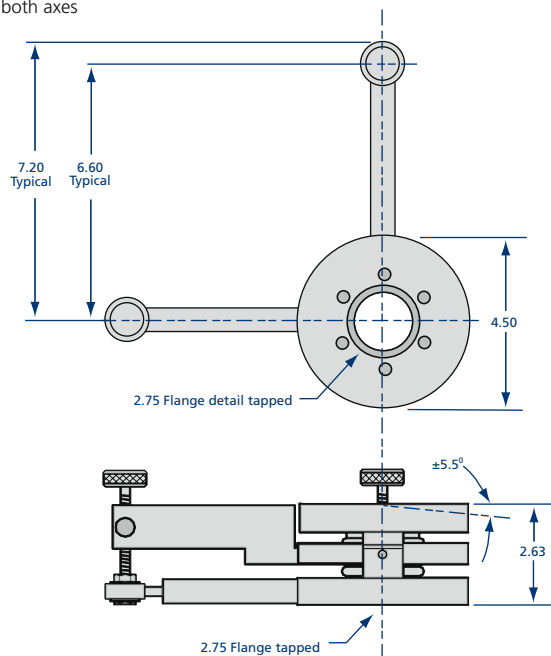

Prices subject to change without notice. - International product pricing will vary.

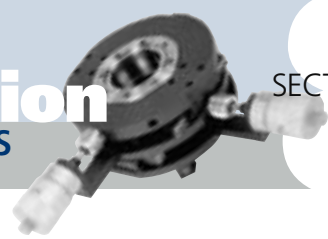

Differentially Pumped Rotary Seals

Differentially pumped rotary seals provide 360° of continuous rotation through the vacuum wall of a UHV system. They have two stages of differential pumping isolated by graphite-impregnated, expanded, Teflon seals on special sealing surfaces. A pre-loaded ball bearing set accurately controls the rotating stage position, allowing the unit to be successfully used with manipulators and other precision positioning devices. For easier and more accurate angle adjustment, a worm drive fine adjust option is available. Rotary seals are also available with an anti-backlash stepping or synchronous motor drive. Sizes up to 4 inch ID are standard, while larger sizes are available on request.

MODEL NUMBER	ID	NOMINAL OD	A	B	C	D	E	F	G	H	VERTICAL PAYLOAD*	HORIZONTAL PAYLOAD*
RS-150	1.53	2 ³ / ₄	4.50	2.99	1.00	3.18	2.75	0.49	0.13	60°	54 lbs.	30 lbs.
RS-150-W	1.53	2 ³ / ₄	5.13	3.38	1.00	4.95	2.75	0.49	0.37	60°	54 lbs.	30 lbs.
RS-250	2.53	4 ¹ / ₂	5.75	3.64	1.36	3.58	4.50	0.49	0.03	45°	90 lbs.	38 lbs.
RS-250-W	2.53	4 ¹ / ₂	6.38	4.20	1.36	6.11	4.50	0.49	0.41	45°	90 lbs.	38 lbs.
RS-400	4.03	6	7.75	4.57	1.68	4.34	6.02	0.37	0.06	45°	144 lbs.	66 lbs.
RS-400-W	4.03	6	8.50	8.25	1.68	9.28	6.02	0.37	0.54	45°	144 lbs.	66 lbs.

*Note: Standard maximum payloads with center of gravity within 10% of the RS ID from the RS centerline when vertical, within one ID of the RS from the RS flange face when horizontal, and certain other size restrictions are met – consult factory.

SPECIFICATIONS

- Construction**
Flanges: CF, tapped holes, one rotational and one stationary
T-wrench included for adjustment
- Motion:** 360° rotation, two stage, differentially pumped with 360° vernier scale
- Operating orientation:** Any
- Temperature**
Maximum bakeout: 150°C
Operating: 20°C (ambient)
- Vacuum range:** ≥ 10⁻¹¹Torr - UHV
- Readability:** Standard scale 1.0°, mechanical counter 0.1°, micro stepped motor drive required for maximum resolution
- Options:** Fine adjust worm drive "-W"; digital counters, stepper motors and other sizes available
- Guarantee:** Five years

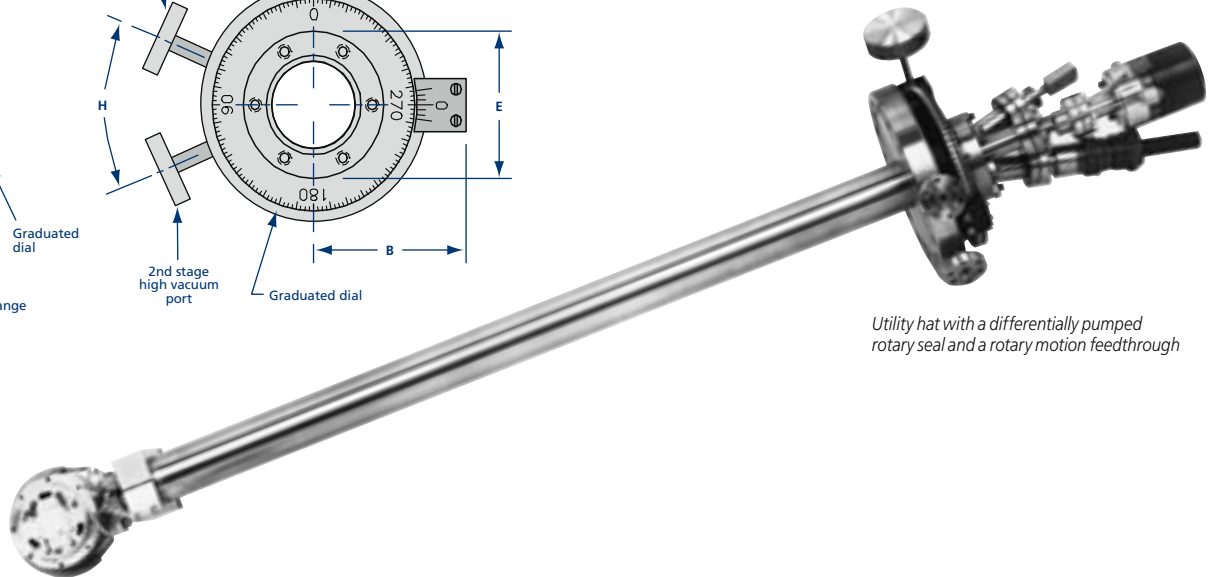
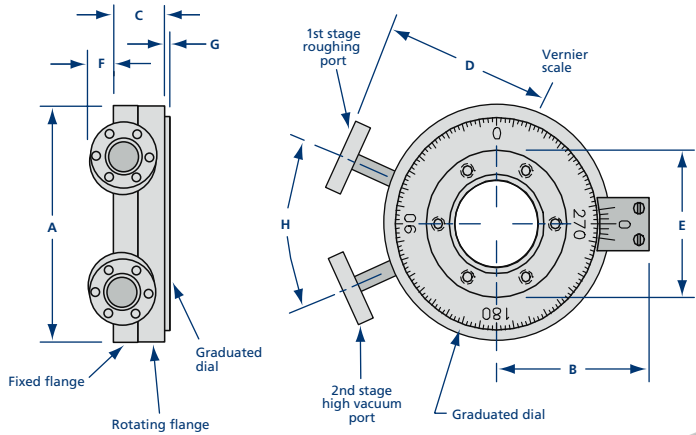

Utility hat with a differentially pumped rotary seal and a rotary motion feedthrough

Motorized Rare Earth Magnetic Rotary Motion Feedthrough

The rare earth magnetic series rotary drives are designed to provide exceptional, long life performance. They are UHV compatible and are an excellent option to conventional bellows sealed and other rotary devices. They can be adapted to pulsed laser deposition (PLD) target clocking and continuous rotation of targets and substrates, as well as applications that require small profiles and high performance. There are no sliding seals or magnets in vacuum and stray magnetic fields are virtually nonexistent. The in-vacuum armature is made of paramagnetic materials with stainless steel and silicon nitride bearings and is capable of repeated bake-out to 200°C with magnets removed. Out-of-vacuum bearings are accessible for lubrication and the magnet drive is easily removable.

SPECIFICATIONS

Construction

Mounting flange: 2³/₄ CF, clearance holes
Rotary probe: ³/₈ inch
Drive: Motor drive with controller, manual drive knob with position lock
Bearings: 4,000,000 revolutions before service

Motion: 360° continuous with variable speed

Operating orientation: Any

Temperature

Maximum bakeout: 200°C, with drive removed
Operating: 20°C (ambient)

Vacuum range: ≥ 10⁻¹⁰Torr - UHV

Torque

Motor: 50 ounce-inches
Feedthrough: 150 ounce-inches

Speed: 5 to 95 RPM

Options: Higher torque motors, different speed ranges

Guarantee: Five years

MODEL NUMBER	FLANGE TYPE	SHAFT OD	SHAFT LENGTH
MRRE-275-038	2.75 CF	0.375	2.75

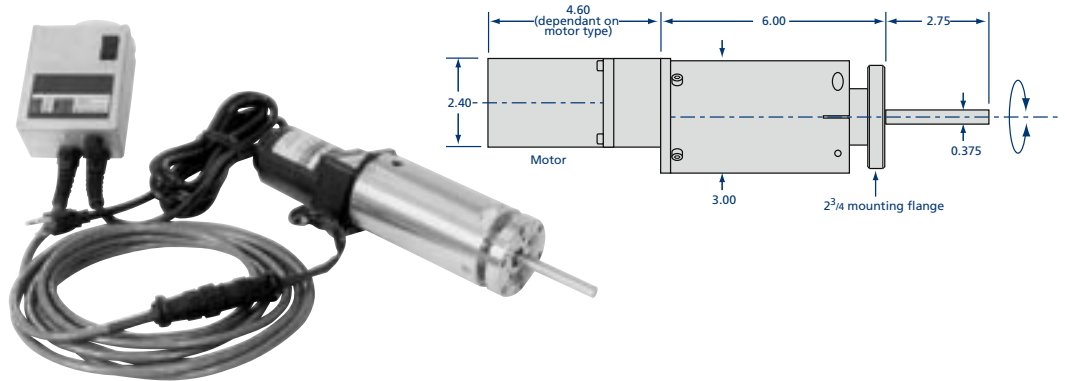

1/4 Inch Precision Rotary Motion Feedthroughs

Precision rotary feedthroughs provide 360° continuous rotation and may be used to define a polar axis for a sample or probe or to actuate a mechanical device, such as a shutter, inside the vacuum chamber. Typically used for polar rotation on top of an XYZ manipulator.

SPECIFICATIONS

Construction

Mounting flange: 1¹/₃ or 2³/₄ CF, clearance holes
Rotary shaft: ¹/₄ inch
Drive: Manually actuated
Attachment: 8-32 tapped hole

Motion: 360° continuous, with 360° graduations on knob and locking screw

Operating orientation: Any

Temperature range: -20°C to 150°C

Vacuum range: ≥ 10⁻¹⁰Torr - UHV

Torque: 50 ounce-inches

Options: Tapped holes, special lengths

MODEL NUMBER	FLANGE TYPE	SHAFT OD	SHAFT LENGTH
PRM-133	1.33 CF	0.25	3.26
PRM-275	2.75 CF	0.25	3.26

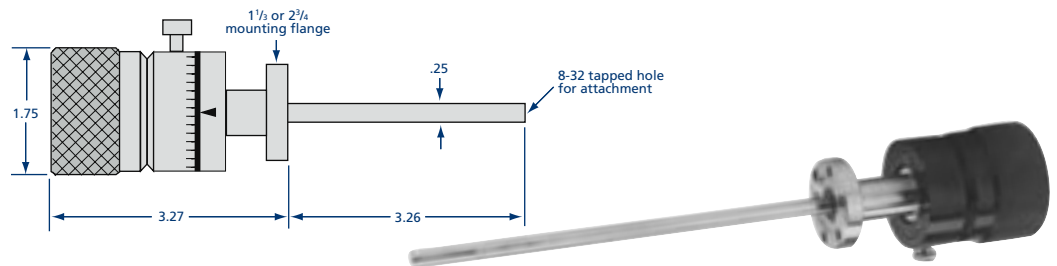

SPECIFICATIONS

Construction

Bellows: Welded stainless steel
Mounting flange: 2³/₄ CF, clearance holes
Rotary shaft: ³/₈ inch
Drive: Manually actuated

Motion: 360° continuous, 0.10° resolution (1° graduations on dial), maximum run-out 0.005 inches

Operating orientation: Any

Temperature

Maximum bakeout: 200°C
Operating: 20°C (ambient)

Vacuum range: ≥ 10⁻¹⁰Torr (UHV)

Torque: 1,100 ounce-inches

Options: Custom shaft lengths: 9 to 23 inches. Change model number suffix "-24" to the desired length and add \$70 to cost. Example: PRM-275-038-12 (indicates 12 inch shaft), field-mountable shaft extensions, fine adjust and motor drives

Guarantee: Five years

3/8 Inch Precision Rotary Motion Feedthrough

Precision rotary feedthroughs are commonly used to define a polar axis for a sample or probe. They provide 360° continuous rotation and are mounted on top of XYZ manipulators and other stages. They are also used separately where precision angular orientation is needed.

MODEL NUMBER	FLANGE TYPE	SHAFT OD	SHAFT LENGTH
PRM-275-038-24	2.75 CF	3/8	24.00

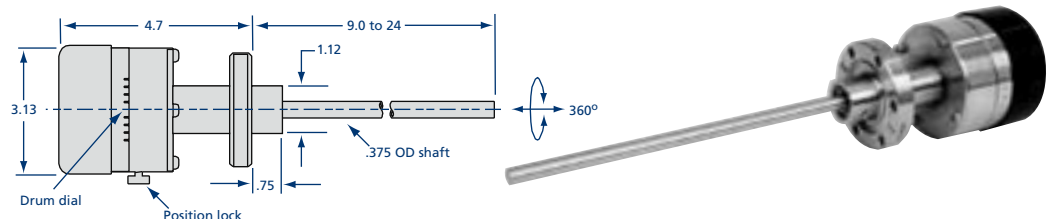

Prices subject to change without notice. - International product pricing will vary.

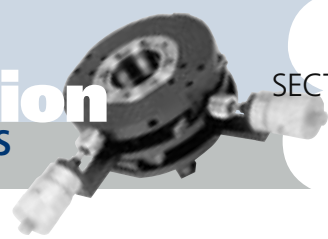

Pneumatically Actuated Linear Motion Feedthrough

Commonly used as positioning devices for shutters and beam stoppers.

MODEL NUMBER	FLANGE TYPE	SHAFT OD	TRAVEL
ALM-133-2	1.33 CF	0.25	2
ALM-133-4	1.33 CF	0.25	4

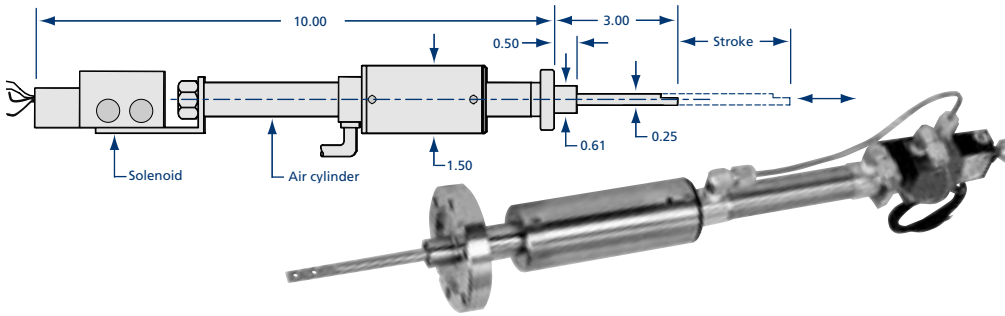

SPECIFICATIONS

Construction
 Bellows: Welded stainless steel, sealed
 Mounting flange: 1¹/₃ CF, clearance holes
 Linear probe: 1/4 inch OD
 Cylinder: 3/4 inch ID
 Bushing: Macor

Motion
 Linear: 2 to 4 inch travel, pneumatically actuated
 Operating air pressure: 50 to 150 psi

Operating orientation: Any

Temperature
 Maximum bakeout: 200°C
 Operating: 20°C (ambient)

Vacuum range: ≥ 10⁻¹⁰Torr - UHV

Options: 2³/₄ inch OD flange

Guarantee: Five years

Heavy-Duty Push-Pull Linear Motion Feedthroughs

Manually operated linear motion positioning device designed for UHV applications.

MODEL NUMBER	FLANGE TYPE	TRAVEL	MINIMUM - MAXIMUM A	B
HLM-275-2	2.75 CF	2	1.1 - 3.1	6.75
HLM-275-3	2.75 CF	3	1.4 - 4.4	8.07
HLM-275-4	2.75 CF	4	1.7 - 5.7	9.38

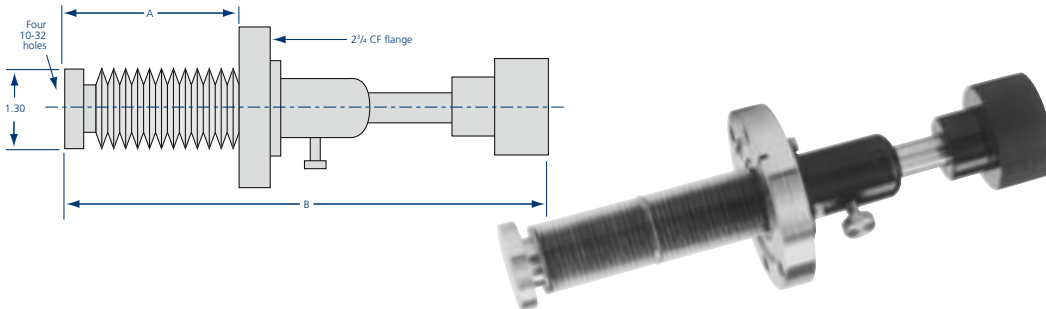

SPECIFICATIONS

Construction
 Bellows: Welded stainless steel, sealed
 Mounting Flange: 2³/₄ CF, clearance holes

Motion: 2, 3 and 4 inch linear travel with

Operating orientation: Any

Temperature range: -20°C to 250°C

Vacuum range: ≥ 10⁻¹⁰Torr - UHV

Maximum lateral load: 20 pounds

Linear Vacuum Feedthrough

Manually operated linear motion positioning device with rotary actuation.

MODEL NUMBER	FLANGE TYPE	LINEAR TRAVEL	SHAFT OD
RLM-133-2	1.33 CF	2	0.25
RLM-133-4	1.33 CF	4	0.25
RLM-275-2	2.75 CF	2	0.25
RLM-275-4	2.75 CF	4	0.25

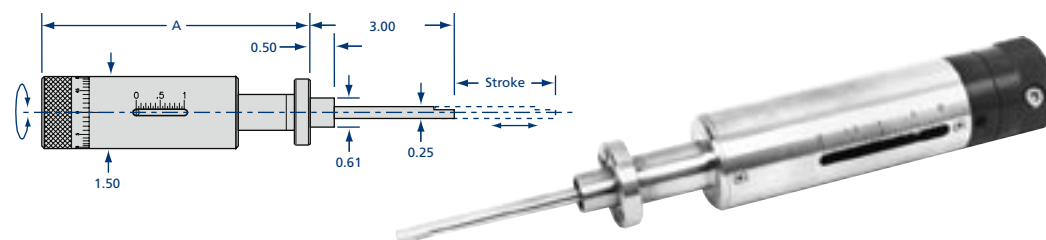

SPECIFICATIONS

Construction
 Bellows: Welded stainless steel, sealed
 Mounting flange: 1¹/₃ or 2³/₄ CF, clearance holes
 Linear shaft: 1/4 inch OD
 Drive: All ball bearing

Motion: 2 or 4 inch linear travel, 20 turns/inch rotary actuation, position indicator

Operating orientation: Any

Temperature
 Maximum bakeout: 200°C
 Operating: 20°C (ambient)

Vacuum range: ≥ 10⁻¹⁰Torr - UHV

Options: Longer strokes

Guarantee: Five years

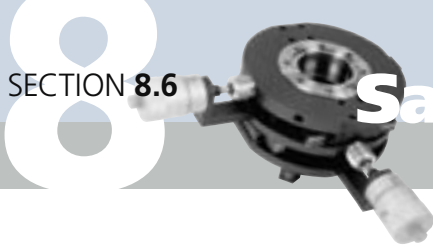

Sample Transfer & Manipulation

Linear/Rotary Motion Feedthroughs

SPECIFICATIONS

Construction

Mounting flange: 2³/₄ CF, clearance holes
 Probe: 1/2 inch OD stainless steel tubular probe
 Drive: Removable neodymium iron boron magnet
 Bearings: 8 stainless steel

Motion

Linear: 24 and 36 inch, adjustable stops
 Rotary: 360° continuous rotation, with 0° to 360° indication

Operating orientation:

Horizontal

Maximum temperature:

200°C with drive removed

Vacuum range:

≥ 10⁻¹⁰Torr (UHV)

Linear force:

4 pounds

Torque:

150 ounce-inches

Options:

Light-touch magnet (-LT)

Guarantee:

Five years

Magnetic Linear/Rotary Feedthrough

Magnetically coupled feedthroughs offer exceptional linear/rotary motion for short to medium stroke sample introduction and transfer of light loads. The standard magnetic driver package provides more than 150 ounce-inches of torque and four pounds of linear force. The inside traveler has no magnets, but it is made of magnetically permeable material.

LIGHT-TOUCH MAGNET ASSEMBLY OPTION (-LT)

- Utilizes dynamically loaded full-bearing support to increase tactile feedback
- Heavy-duty linear magnet driver increases linear force to 15 pounds

MODEL NUMBER	DESCRIPTION
MLR-275-050-24	24 inch stroke
MLR-275-050-36	36 inch stroke
-LT	Light-touch magnet assembly option (Add -LT to the model number)

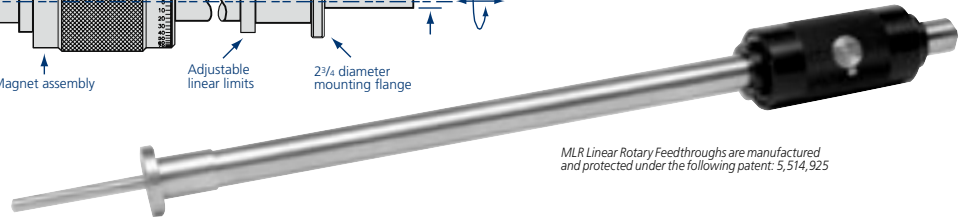
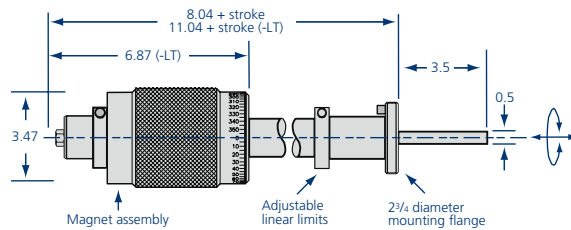

MLR Linear Rotary Feedthroughs are manufactured and protected under the following patent: 5,514,925

Coaxial Magnetic Linear/Rotary Feedthrough

Magnetically-coupled linear/rotary feedthroughs offer unparalleled smooth rotary motion for medium to long stroke sample introduction and transfer of light loads. The coaxial design features a 3/4 inch linear support tube with rotary bearing in the tip to guide the 1/4 inch rotary probe. In addition to rotary motion, the design includes a linear driver, for additional axial force and tactile feedback.

SOFT-TOUCH MAGNET ASSEMBLY OPTION (-ST)

Soft touch magnet assembly utilizes dynamically loaded full-bearing support to increase tactile feedback.

MODEL NUMBER	DESCRIPTION
MLRC-275-36	36 inch stroke
MLRC-275-42	42 inch stroke
MLRC-275-48	48 inch stroke
-ST	Soft-touch magnet assembly option (Add -ST to model number)

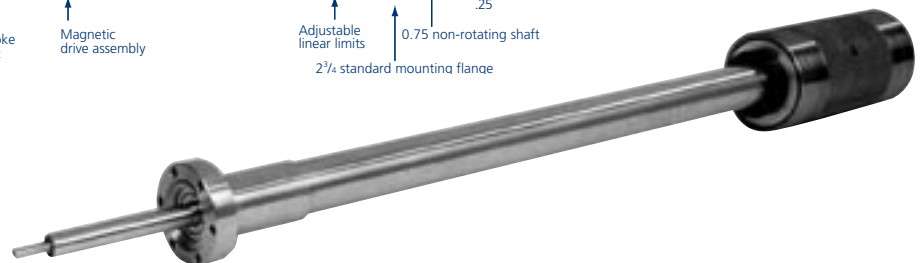
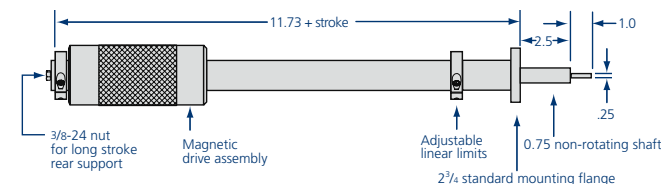

SPECIFICATIONS

Construction

Mounting flange: 2³/₄ CF, clearance holes
 Linear shaft: 3/4 inch
 Rotary probe: 1/4 inch
 Drive: Removable neodymium iron boron magnet
 Bearings: Precision internal guide

Motion

Linear: Up to 48 inch
 Rotary: 360° continuous

Operating orientation:

Horizontal

Temperature

Maximum bakeout: 200°C, drive removed
 Operating: 20°C (ambient)

Vacuum range:

≥ 10⁻¹⁰Torr (UHV)

Linear force:

15 pounds

Torque:

150 ounce-inches

Options:

Soft-touch magnet (-ST)

Guarantee:

Five years

Prices subject to change without notice. - International product pricing will vary.

Ultra-High Vacuum Components Since 1962 • 800-824-4166 • www.n-c.com

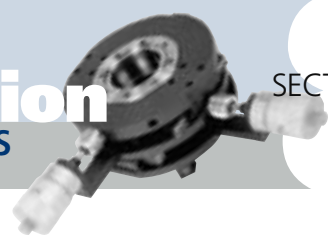

Differentially Pumped Linear/Rotary Motion Feedthrough

MODEL NUMBER	SEAL	DESCRIPTION	MAXIMUM A
OLR-275-10	Viton	Manually operated, for medium vacuum applications	15.20

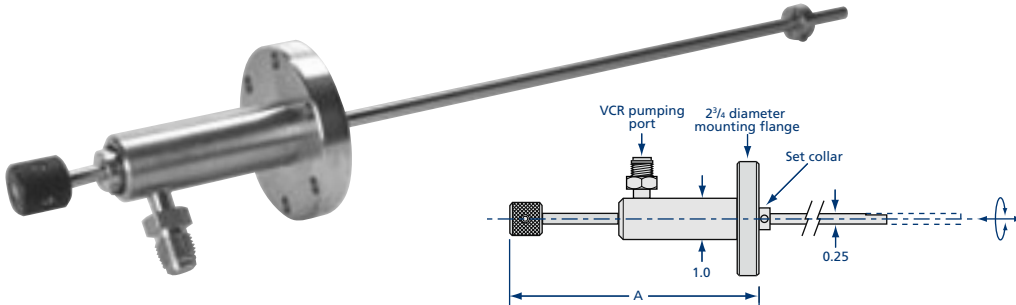

SPECIFICATIONS

Construction
 Feedthrough: stainless steel
 Mounting flange: 2³/₄ CF, clearance holes
 Probe: 1/4 inch OD
 Seal: Differentially pumped Viton O-ring
 Body insert: Teflon

Motion
 Linear: 24 inch, clamp type stop collar
 Rotary: 360° continuous rotation

Operating orientation: Any

Temperature range: -20°C to 150°C

Vacuum range: ≥ 10⁻⁵Torr - Medium vacuum

Guarantee: Five years

Precision Linear/Rotary Motion Feedthrough

MODEL NUMBER	DESCRIPTION	STROKE
PLR-275-050	Stand-alone device or used when coupled with a gearbox to control polar and azimuthal rotation of a sample	1/2

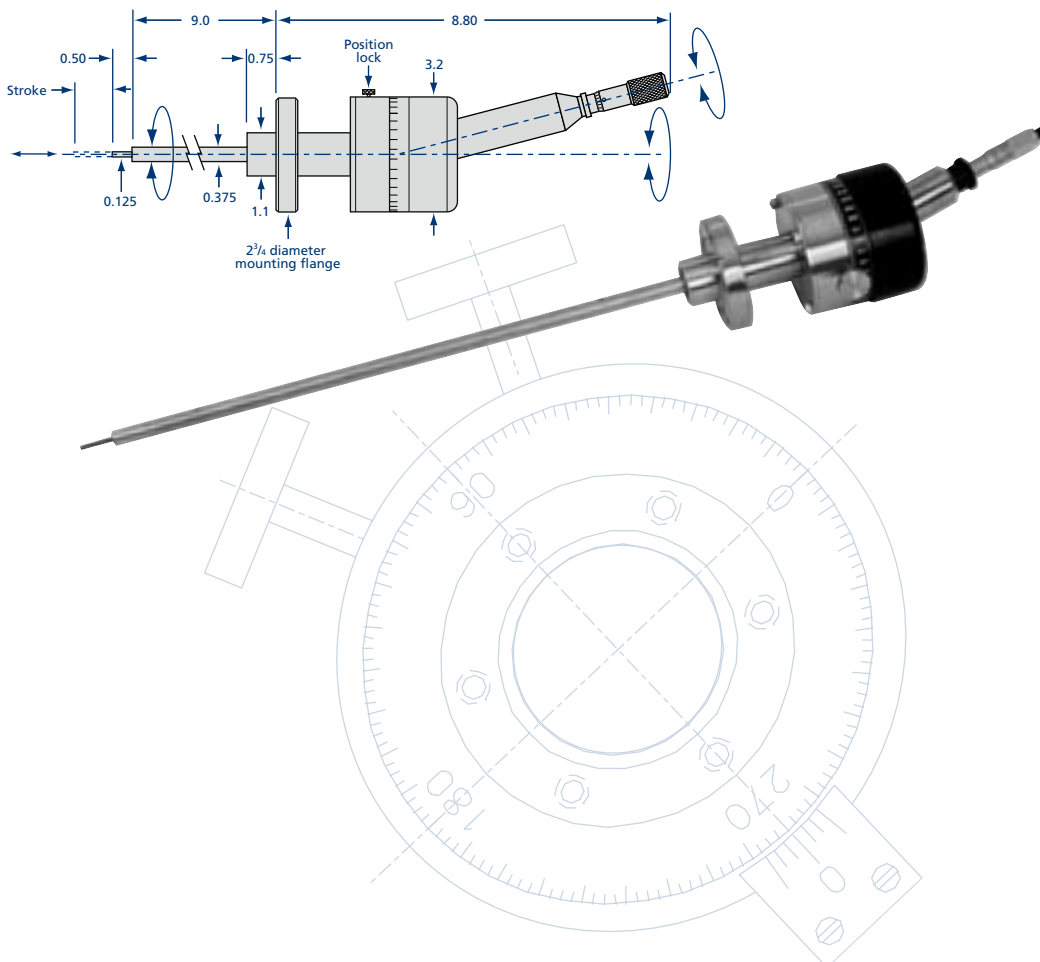

SPECIFICATIONS

Construction
 Mounting flange: 2³/₄ CF, clearance holes
 Linear probe: 1/8 inch OD
 Rotary tube: 3/8 inch OD, 9 inch length
 Bearings: Precision internal guide

Motion
 Linear: 1/2 inch, micrometer adjusted
 Rotary: 360° continuous, 0.1° resolution
 in 1.0° graduations with position lock

Operating orientation: Any

Temperature
 Maximum bakeout: 200°C
 Operating: 20°C (ambient)

Vacuum range: ≥ 10⁻⁸Torr - UHV

Guarantee: Five years



Sample Transfer & Manipulation

Wobble Sticks

Wobble Sticks

WBL wobble sticks offer a simple means of positioning samples in vacuum by permitting Z-axis and tilt movements. All stainless steel construction designed for use in high vacuum or UHV environments.

SPECIFICATIONS

Construction

Bellows: Welded stainless steel
Mounting flange: CF or NW
Shaft OD: 1/8 or 1/4 inch
Drive: Manually actuated

Motion: $\pm 22^\circ$ or $\pm 30^\circ$ tilt

Operating orientation: Any

Temperature range

Metal seal: 450°C
Elastomer seal: 200°C

Vacuum range

Metal seal: $\geq 10^{-10}$ Torr (UHV)
Elastomer seal: $\geq 10^{-8}$ Torr (High Vacuum)

MODEL NUMBER	FLANGE TYPE	FLEX ANGLE*	A	B	MIN. - MAX. C
WBL-133	1.33 CF	$\pm 22^\circ$	6	0.12	3 - 3 1/2
WBL-275	2.75 CF	$\pm 30^\circ$	10	0.25	3 3/4 - 6
WBL-NW-16	NW-16	$\pm 22^\circ$	6	0.12	3 - 3 1/2
WBL-NW-40	NW-40	$\pm 30^\circ$	10	0.25	3 3/4 - 6

* Mating flange may restrict flexible angle

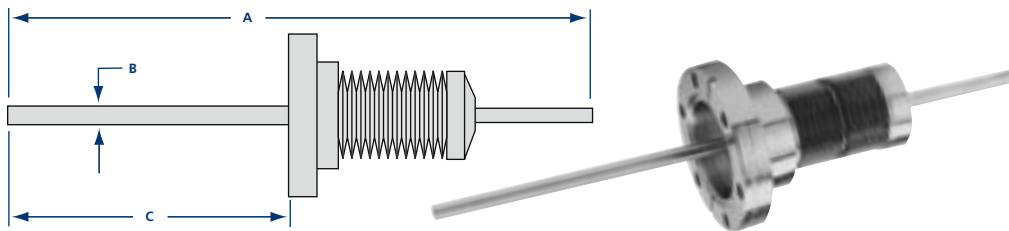

Rotary Wobble Sticks

RWS wobble sticks provide Z-axis, polar rotation, and polar axis tilt to allow tip positioning inside a vacuum chamber. They offer an inexpensive alternative for sample introduction and manipulation.

SPECIFICATIONS

Construction

Bellows: Welded stainless steel, independent for Z and theta
Mounting flange: 2 3/4 CF, clearance holes
Tip: Pre-fitted with hook
Drive: Manually actuated

Motion

Rotary: 360° probe rotation via rotary motion feedthrough
Linear: 4 or 8 inch stroke
Tilt: $\pm 22^\circ$

Operating orientation: Any

Temperature

Maximum bakeout: 200°C
Operating: 20°C (ambient)

Vacuum range: $\geq 10^{-10}$ Torr -UHV

Options: Single-jaw pincer (add "-PS" to model number), double-jaw Omicron and other pincers upon request

Guarantee: Five years

MODEL NUMBER	FLANGE TYPE	FLEX ANGLE*	Z STROKE
RWS-275-4	2.75 CF	$\pm 22^\circ$	4
RWS-275-8	2.75 CF	$\pm 22^\circ$	8

-PS Single Jaw Pincer Option Add -PS to model number

* Mating flange may restrict flexible angle

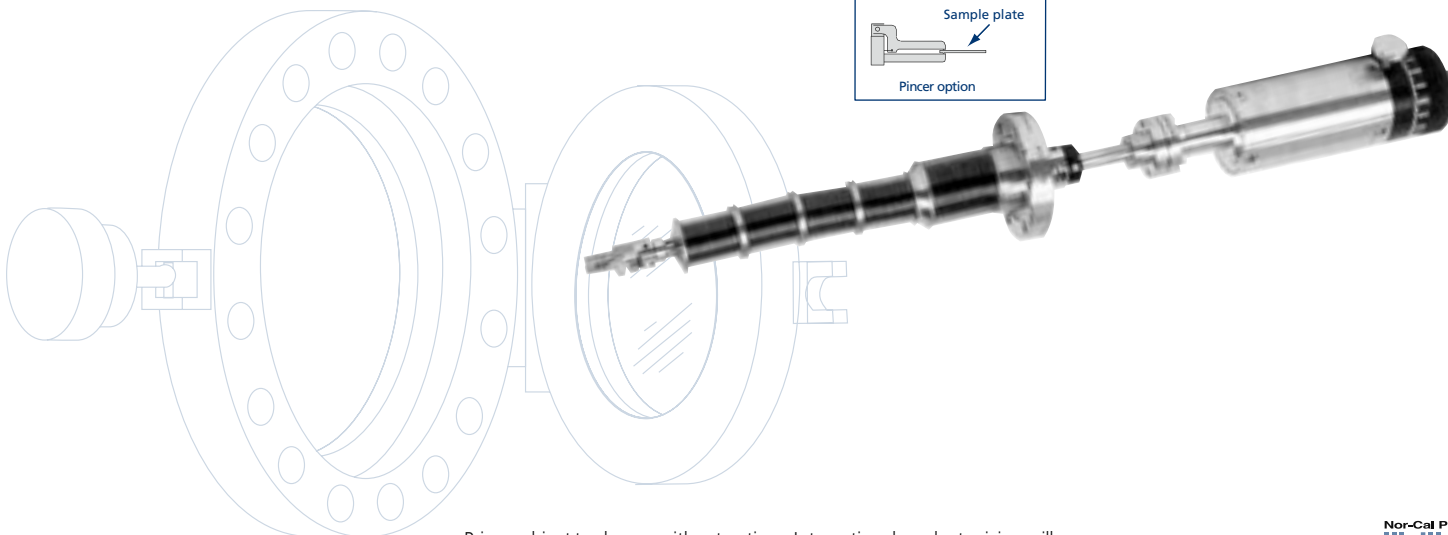
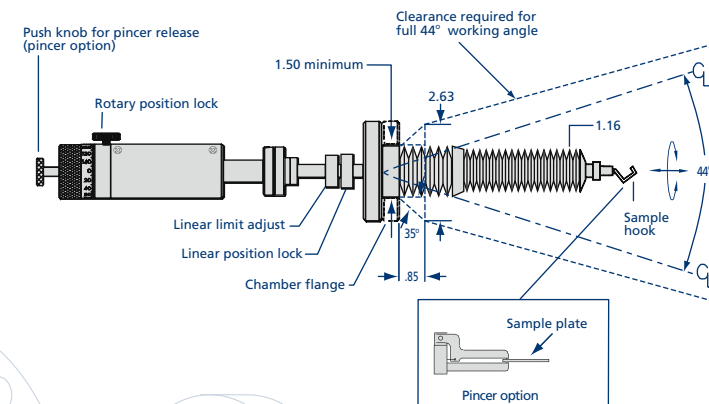

Prices subject to change without notice. - International product pricing will vary.